



Product Summary

$V_{(BR)DSS}$	$R_{DS(on)TYP}$	I_D
500V	3.6Ω@10V	1.7A

Feature

- Low $R_{DS(ON)}$
- Low FOM
- Extremely low switching loss
- Good stability and uniformity

Application

- Consumer electronics power supply
- PWM Application
- Standby Power
- Charger

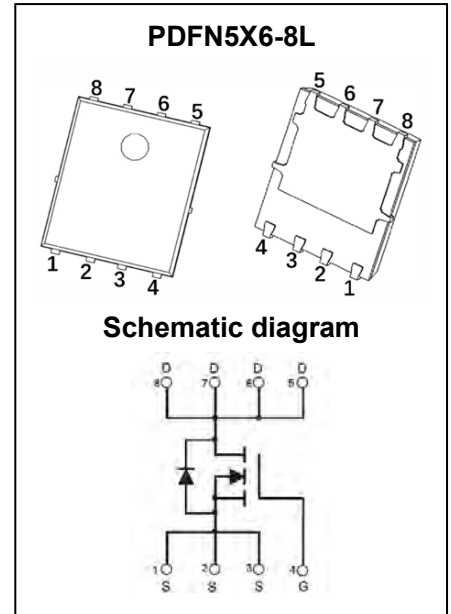

Package Marking and Ordering Information

Part Number	Package	Marking	Packing	Reel Size	Tape Width	Qty
GP04N50NC	PDFN5X6-8L	04N50	Reel & Tape	330mm	12mm	5000pcs

ABSOLUTE MAXIMUM RATINGS ($T_A = 25^\circ\text{C}$ unless otherwise noted)

Parameter	Symbol	Value	Unit
Drain-Source Voltage	V_{DS}	500	V
Gate-Source Voltage	V_{GS}	±30	V
Continuous Drain Current ¹	I_D	1.7	A
Pulsed Drain Current ²	I_{DM}	6.8	A
Single Pulsed Avalanche Current ³	I_{AS}	2.9	A
Single Pulsed Avalanche Energy ³	E_{AS}	2.1	mJ
Power Dissipation ⁵	P_D	25	W
Thermal Resistance from Junction to Ambient ⁶	$R_{\theta JA}$	100	°C /W
Thermal Resistance from Junction to Case	$R_{\theta JC}$	5	°C /W
Junction Temperature	T_J	150	°C
Storage Temperature	T_{STG}	-55~ +150	°C

MOSFET ELECTRICAL CHARACTERISTICS (T_A = 25°C unless otherwise noted)

Parameter	Symbol	Test Condition	Min	Type	Max	Unit
Off Characteristics						
Drain-Source Breakdown Voltage	V _{(BR)DSS}	V _{GS} = 0V, I _D = 250μA	500			V
Zero Gate Voltage Drain Current	I _{DSS}	V _{DS} = 500V, V _{GS} = 0V			1	μA
Gate-Body Leakage Current	I _{GSS}	V _{GS} = ±30V, V _{DS} = 0V			±100	nA
On Characteristics⁴						
Gate Threshold Voltage	V _{GS(th)}	V _{DS} = V _{GS} , I _D = 250μA	2	3	4	V
Drain-Source On-Resistance	R _{DS(on)}	V _{GS} = 10V, I _D = 1.5A		3.6	4.2	Ω
Dynamic Characteristics						
Input Capacitance	C _{iss}	V _{DS} = 250V, V _{GS} = 0V, f = 0.1MHz		178		pF
Output Capacitance	C _{oss}			8.9		
Reverse Transfer Capacitance	C _{rss}			2.3		
Gate Resistance	R _g	V _{DS} = 0V, V _{GS} = 0V, f = 1MHz		5.6		Ω
Switching Characteristics						
Total Gate Charge	Q _g	V _{DS} = 280V, V _{GS} = 10V, I _D = 1.5A		8.2		nC
Gate-Source Charge	Q _{gs}			1.8		
Gate-Drain Charge	Q _{gd}			3.2		
Turn-On Delay Time	t _{d(on)}	V _{DD} = 100V, V _{GS} = 10V, I _D = 1.5A, R _G = 25Ω		5		ns
Turn-On Rise Time	t _r			17		
Turn-Off Delay Time	t _{d(off)}			24		
Turn-Off Fall Time	t _f			26		
Source-Drain Diode Characteristics						
Diode Forward Voltage ⁴	V _{SD}	V _{GS} = 0V, I _S = 1A			1.2	V

Notes :

- 1.The maximum current rating is limited by package.And device mounted on a large heatsink
- 2.Pulse Test : Pulse Width ≤ 10μs, duty cycle ≤ 1%.
- 3.EAS condition: V_{DD} = 100V, V_{GS} = 10V, L = 2mH, R_G = 25Ω Starting T_J = 25°C .
- 4.Pulse Test : Pulse Width ≤ 300μs, duty cycle ≤ 2%.
- 5.The power dissipation P_D is limited by T_{J(MAX)} = 150°C.And device mounted on a large heatsink
- 6.Device mounted on 1in² FR-4 board with 2oz. Copper, in a still air environment with T_A =25°C.

Typical Characteristics

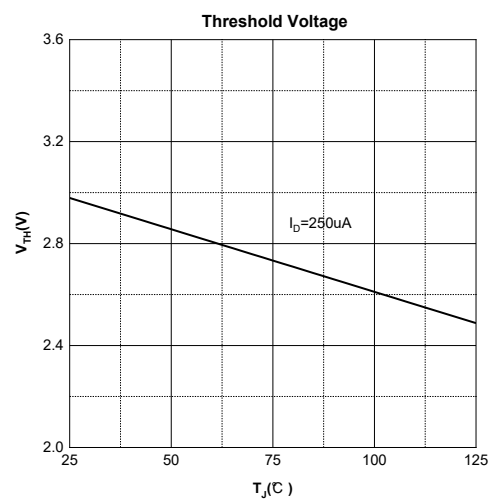
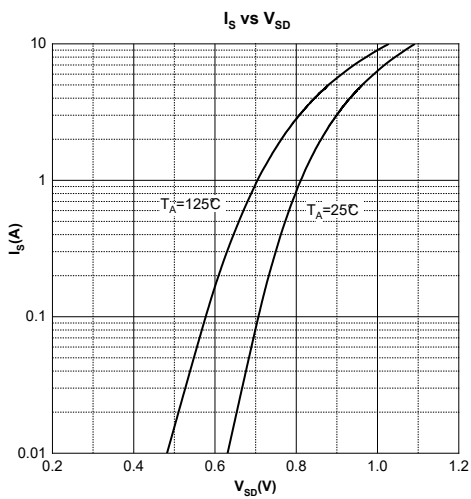
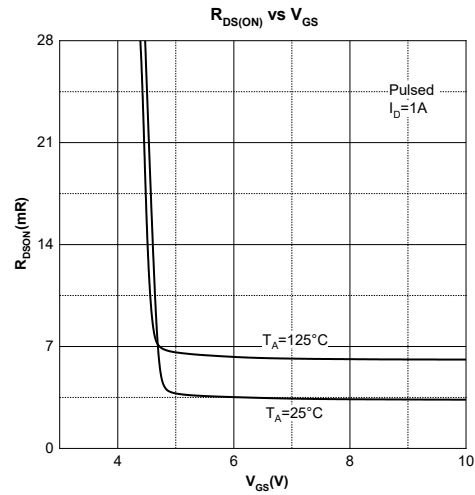
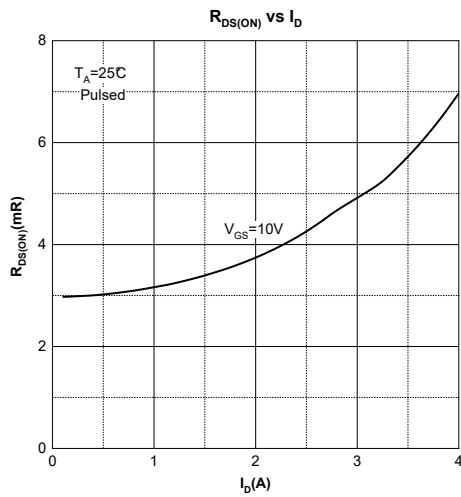
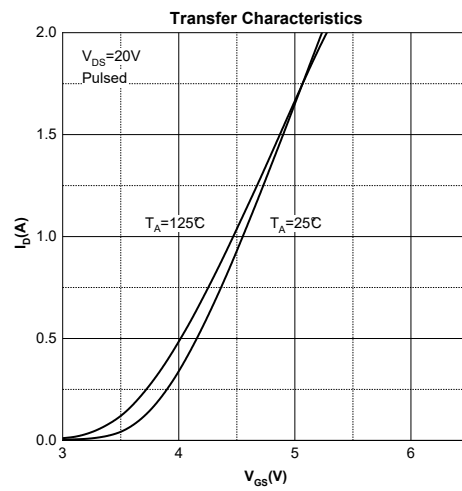
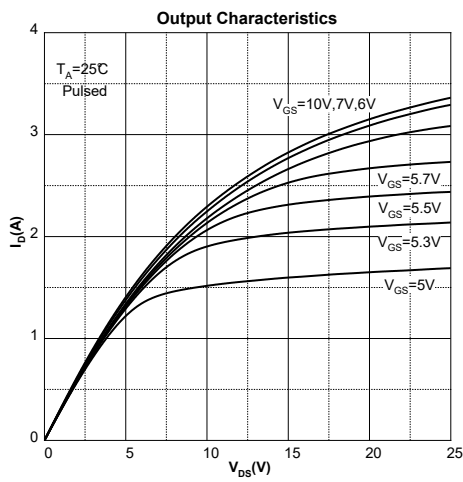

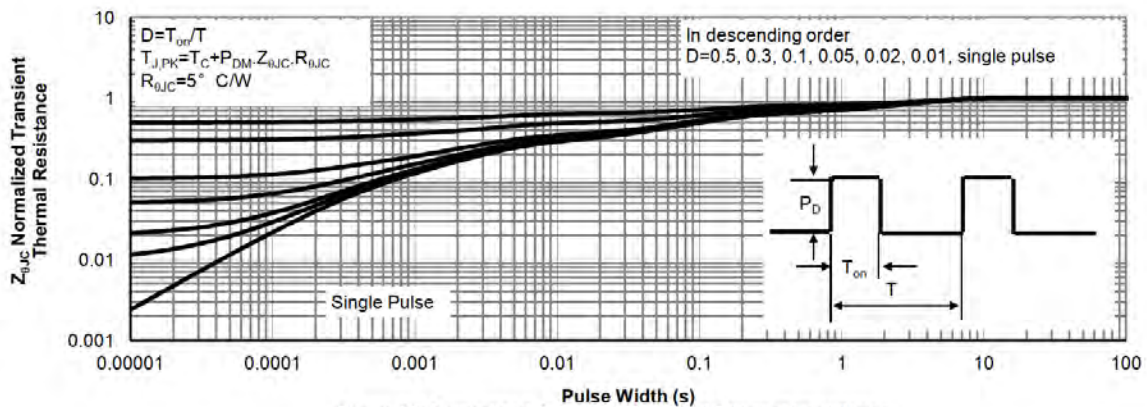
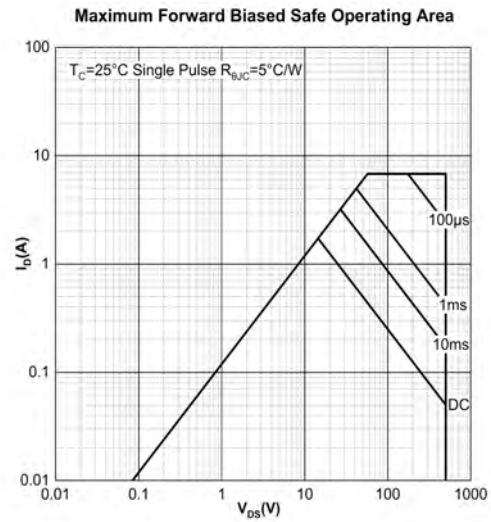
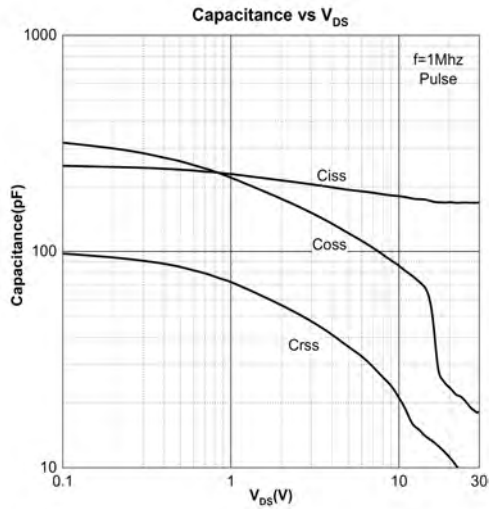

Gate Charge Test Circuit & Waveform

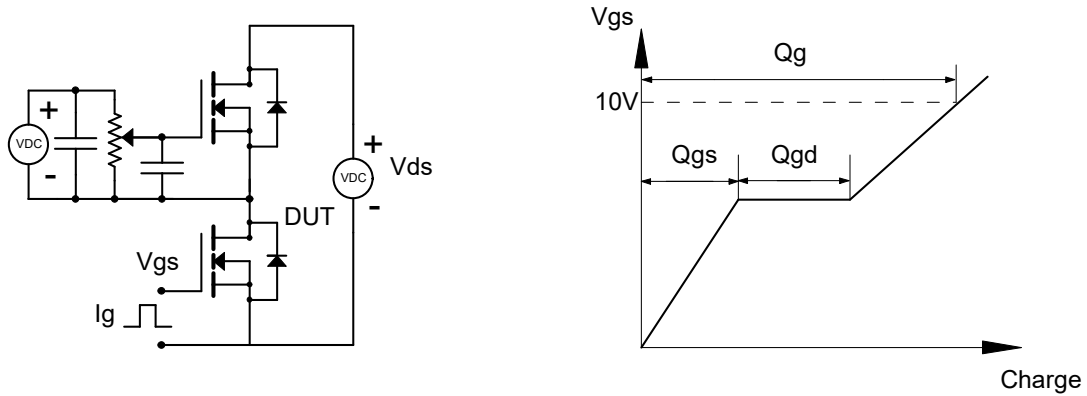

Resistive Switching Test Circuit & Waveform

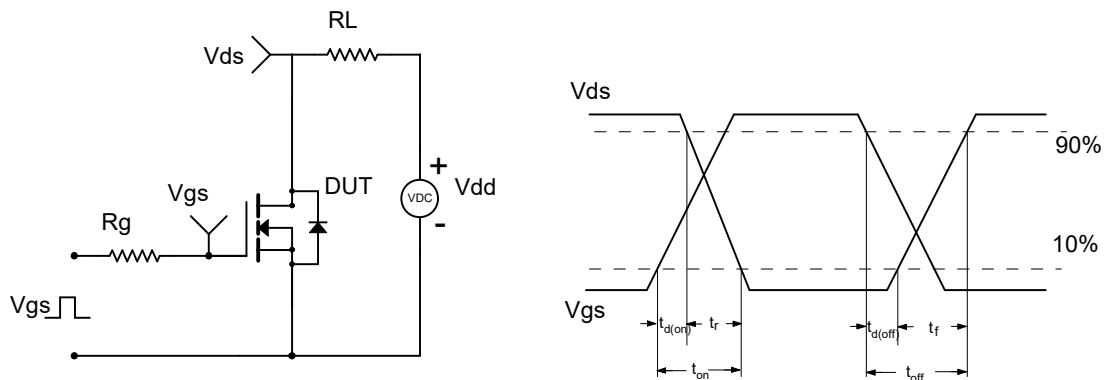

Unclamped Inductive Switching (UIS) Test Circuit & Waveforms

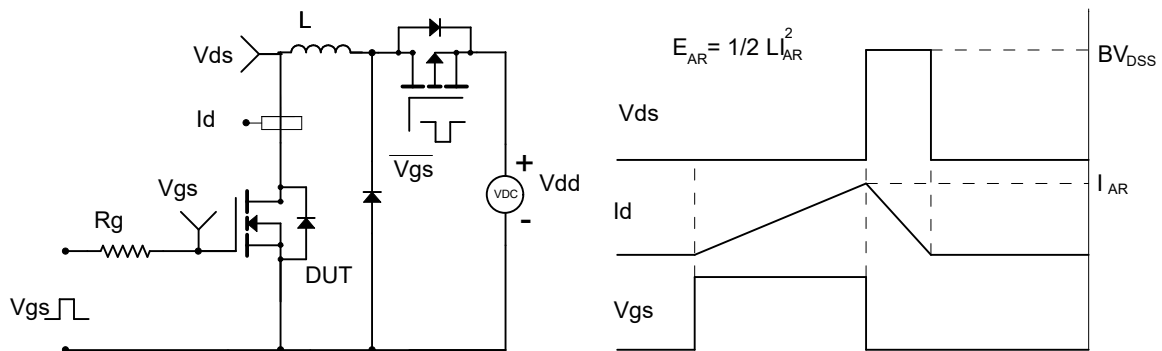

PDFN5X6-8L Package Information

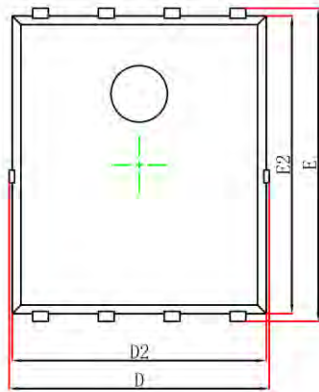

Top View
[顶视图]

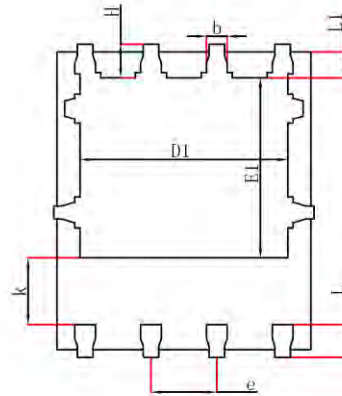

Bottom View
[背视图]

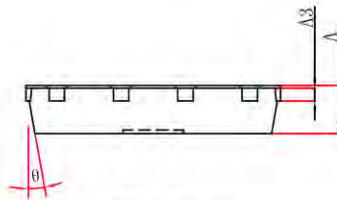

Side View
[侧视图]

Symbol	Dimensions In Millimeters		Dimensions In Inches	
	Min.	Max.	Min.	Max.
A	0.900	1.10	0.035	0.043
A3	0.254REF		0.010REF	
D	4.700	5.260	0.185	0.207
E	5.750	6.250	0.226	0.246
D1	3.560	4.500	0.140	0.177
E1	3.180	3.660	0.125	0.144
D2	4.700	5.100	0.185	0.201
E2	5.600	6.000	0.220	0.236
k	1.100	-	0.043	-
b	0.300	0.500	0.012	0.020
e	1.270TYP		0.050TYP	
L	0.510	0.710	0.020	0.028
L1	0.424	0.576	0.017	0.023
H	0.510	0.710	0.020	0.028
θ	8°	12°	8°	12°

Attention:

- GreenPower Electronics reserves the right to improve product design function and reliability without notice.
- Any and all semiconductor products have certain probability to fail or malfunction, which may result in personal injury, death or property damage. Customer are solely responsible for providing adequate safe measures when design their systems.
- GreenPower Electronics products belong to consumer electronics or other civilian electronic products.